



Diagnostic Sonar

Recent advances in aerospace
inspection with ultrasonic
phased arrays



David Lines

Chief Engineer, Diagnostic Sonar Ltd., UK

AeroNDT SEMINAR, Aerospace Testing Expo2007
27th-29th March 2007, Munich



Content

- Background
 - Arrays and real-time imaging
 - Advanced acquisition techniques
 - New possibilities of Full Raw Data (FRD)
- Application Examples
 - Non-linear processing
 - Composite spar inspection
 - 2nd layer crack detection

Arrays – Stepped scanning

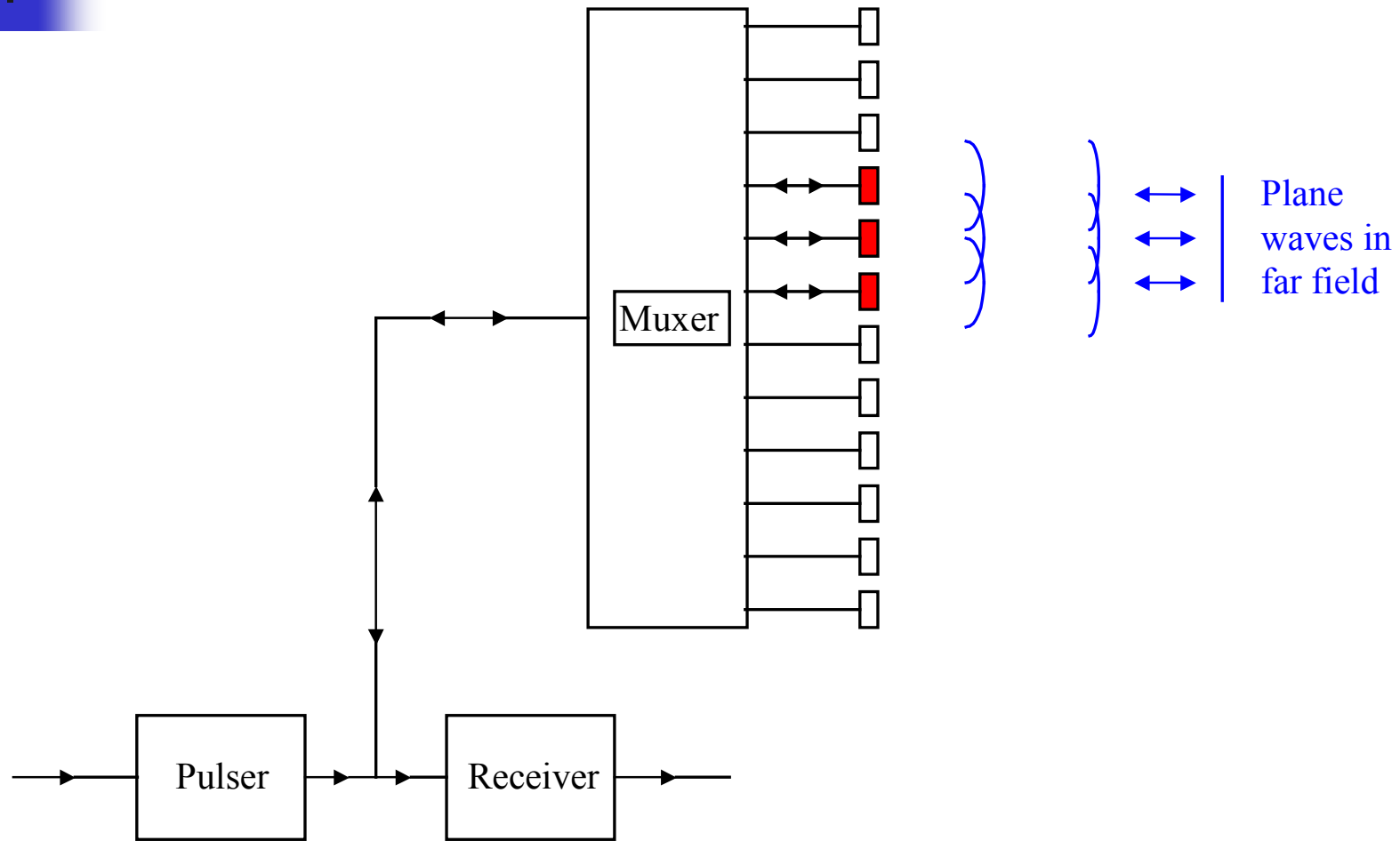

Arrays – Electronic focusing

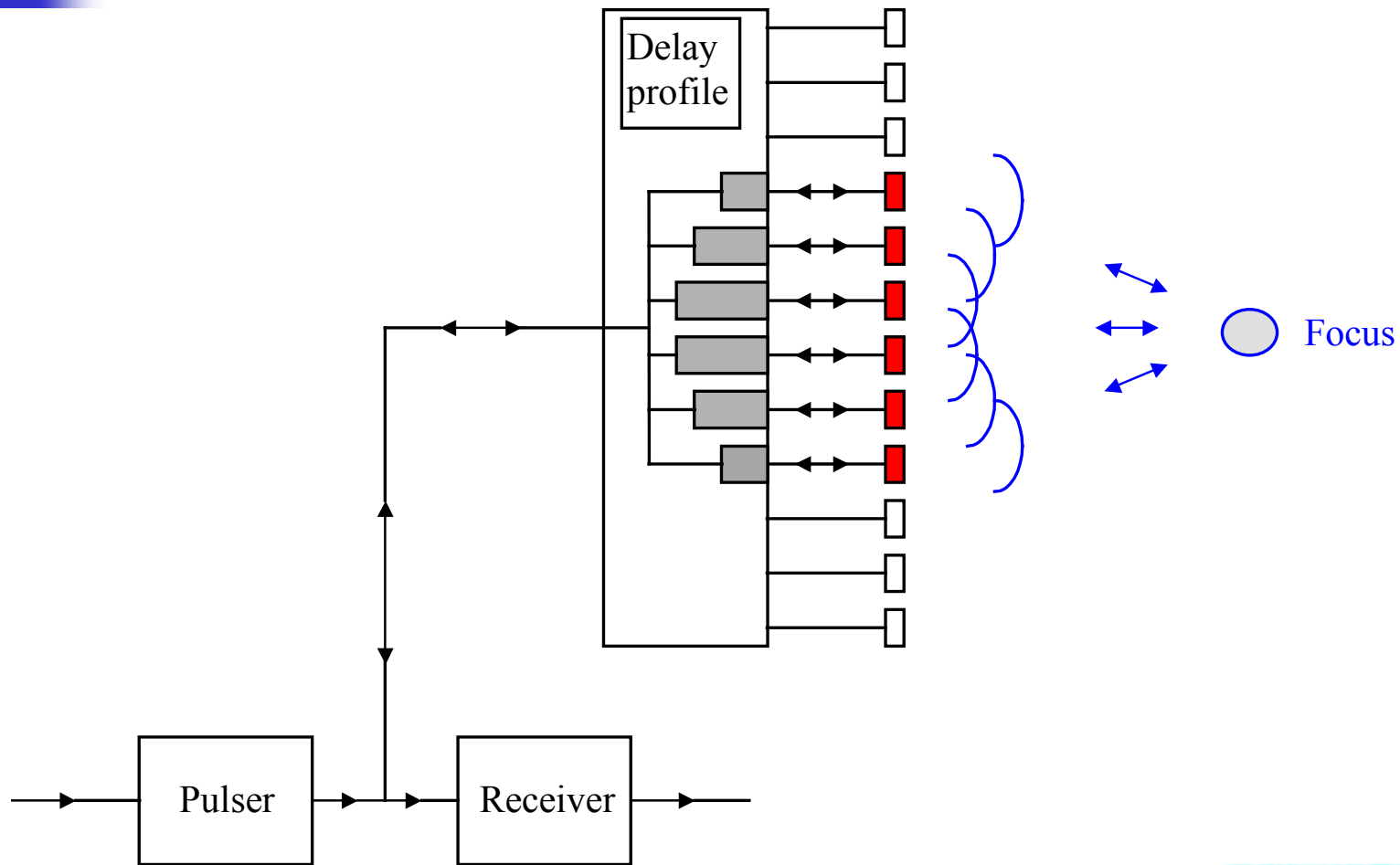

Recent advances in aerospace inspection with ultrasonic phased arrays
Aerospace Testing Expo2007, Munich

Dynamic focusing

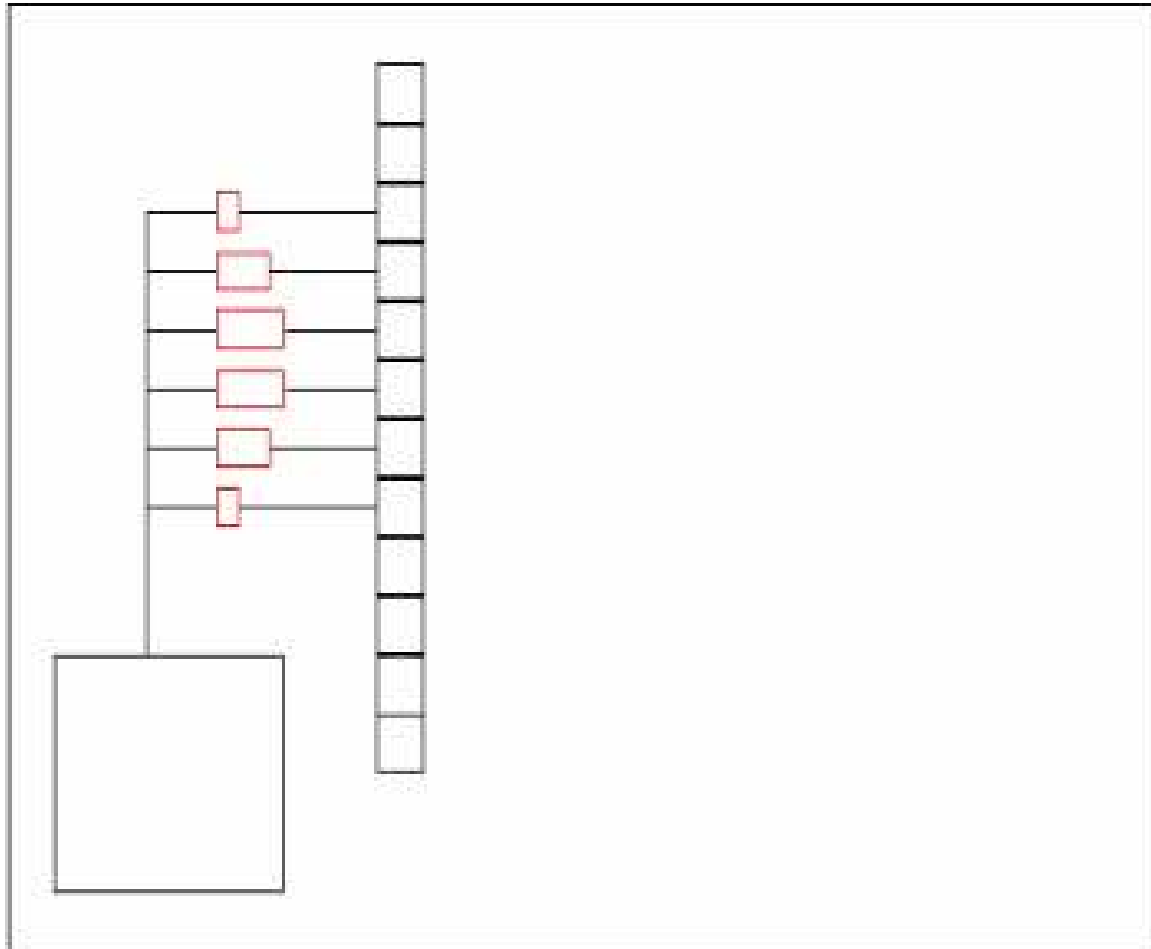

Recent advances in aerospace inspection with ultrasonic phased arrays
Aerospace Testing Expo2007, Munich

Arrays – Steered and focused

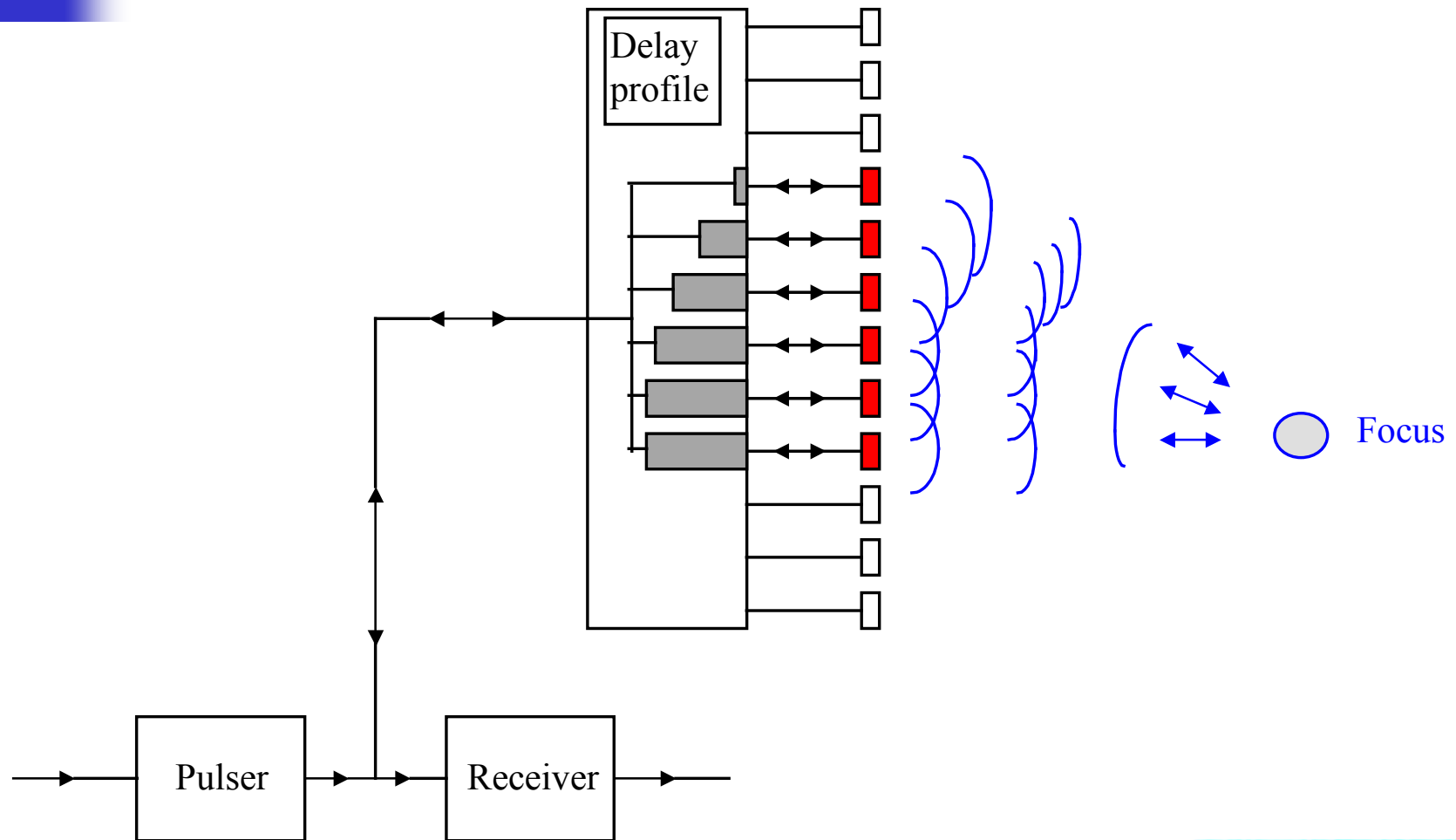

Recent advances in aerospace inspection with ultrasonic phased arrays
Aerospace Testing Expo2007, Munich



What is Distributed Data Collection?

- Coherent RF data set composed of pitch-catch combinations from different locations
- In general
 - No restriction in location in any dimension
 - Tx and Rx sensors can have different beam properties
- Common characteristics
 - Tx and Rx sensor beam properties usually same
 - Beam width is usually much wider than for imaging. Images are then generated by beamforming on the RF data

Array distributed data collection

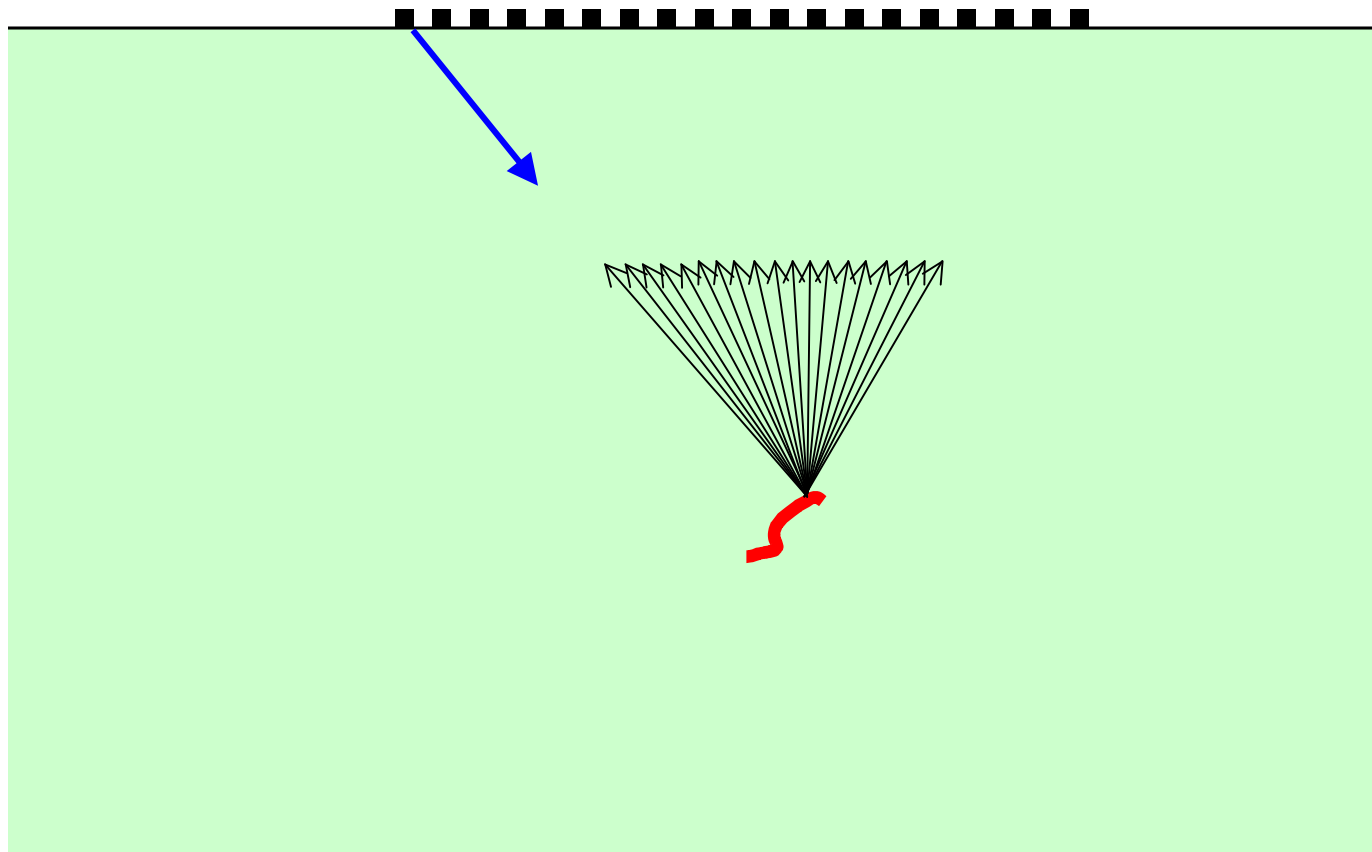

Recent advances in aerospace inspection with ultrasonic phased arrays
Aerospace Testing Expo2007, Munich



Array distributed data collection

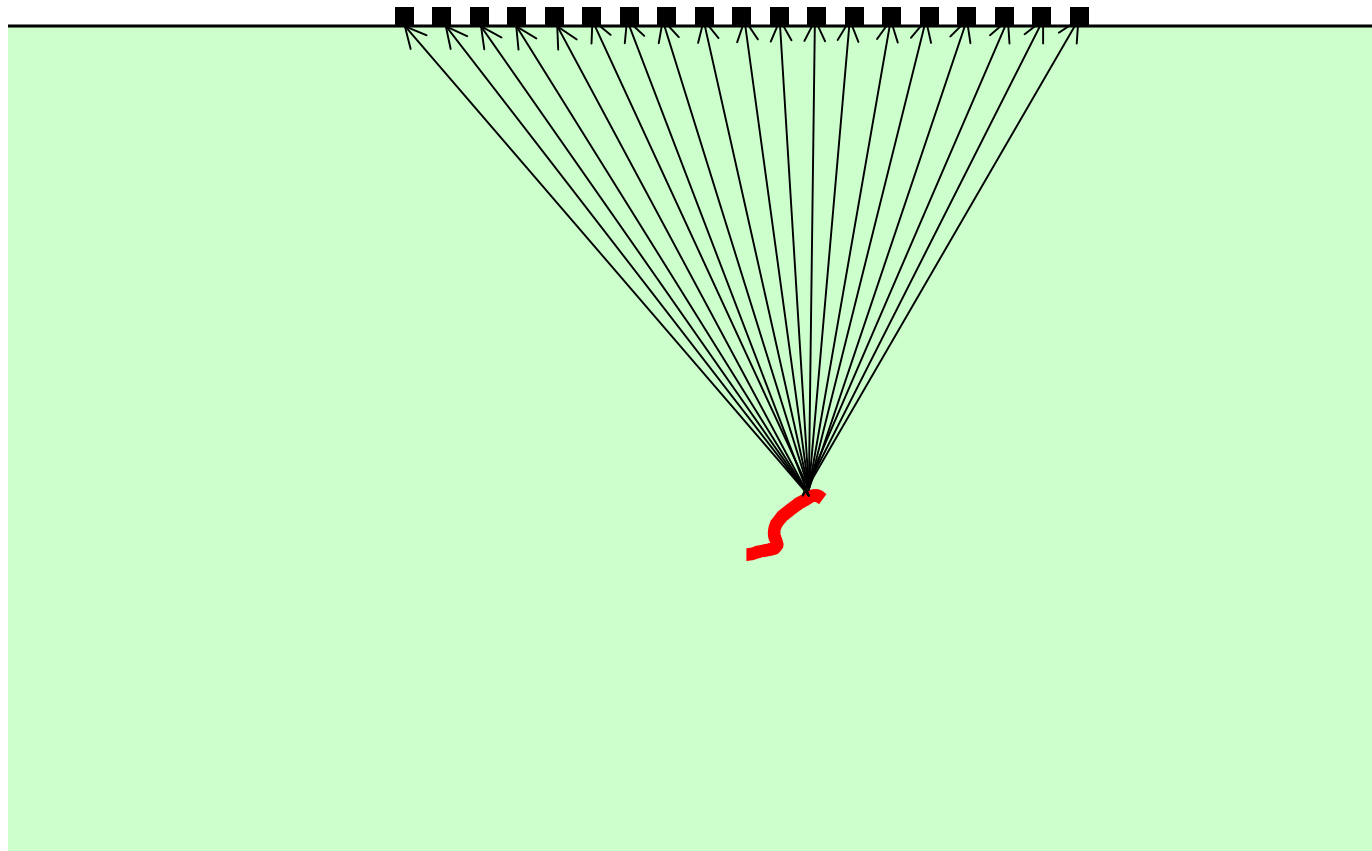

Recent advances in aerospace inspection with ultrasonic phased arrays
Aerospace Testing Expo2007, Munich

Array distributed data collection

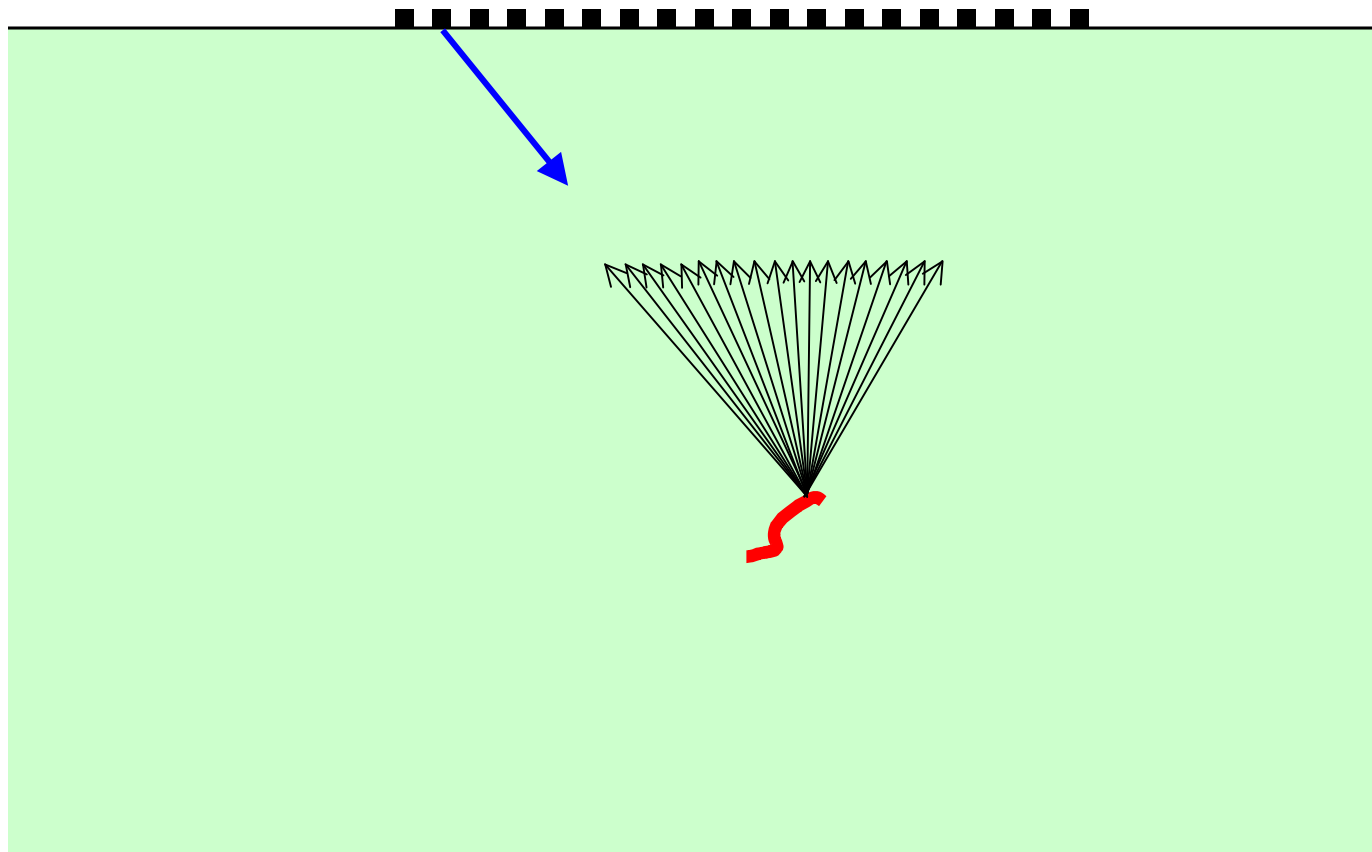

Recent advances in aerospace inspection with ultrasonic phased arrays
Aerospace Testing Expo2007, Munich

Array distributed data collection

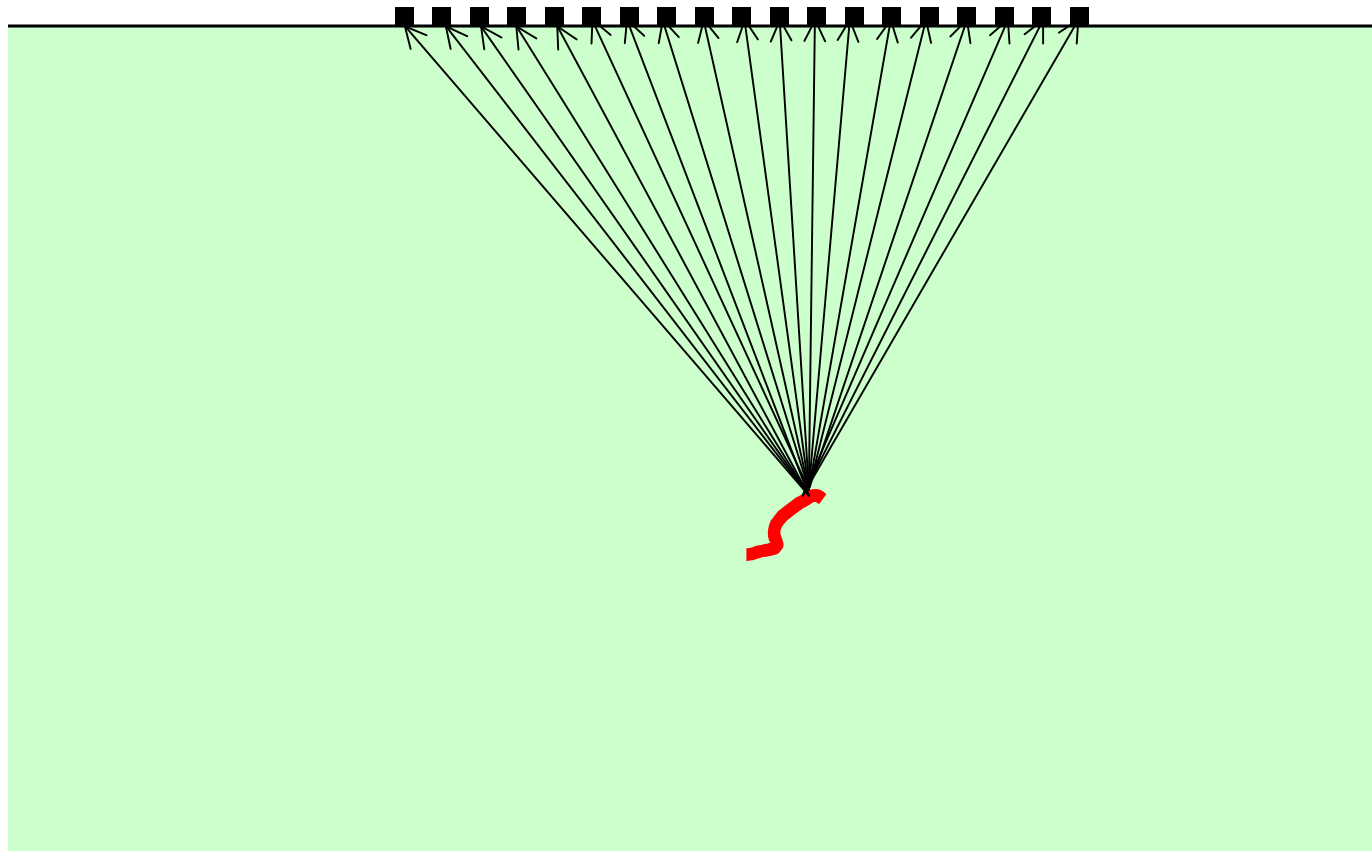

Recent advances in aerospace inspection with ultrasonic phased arrays
Aerospace Testing Expo2007, Munich

Array distributed data collection

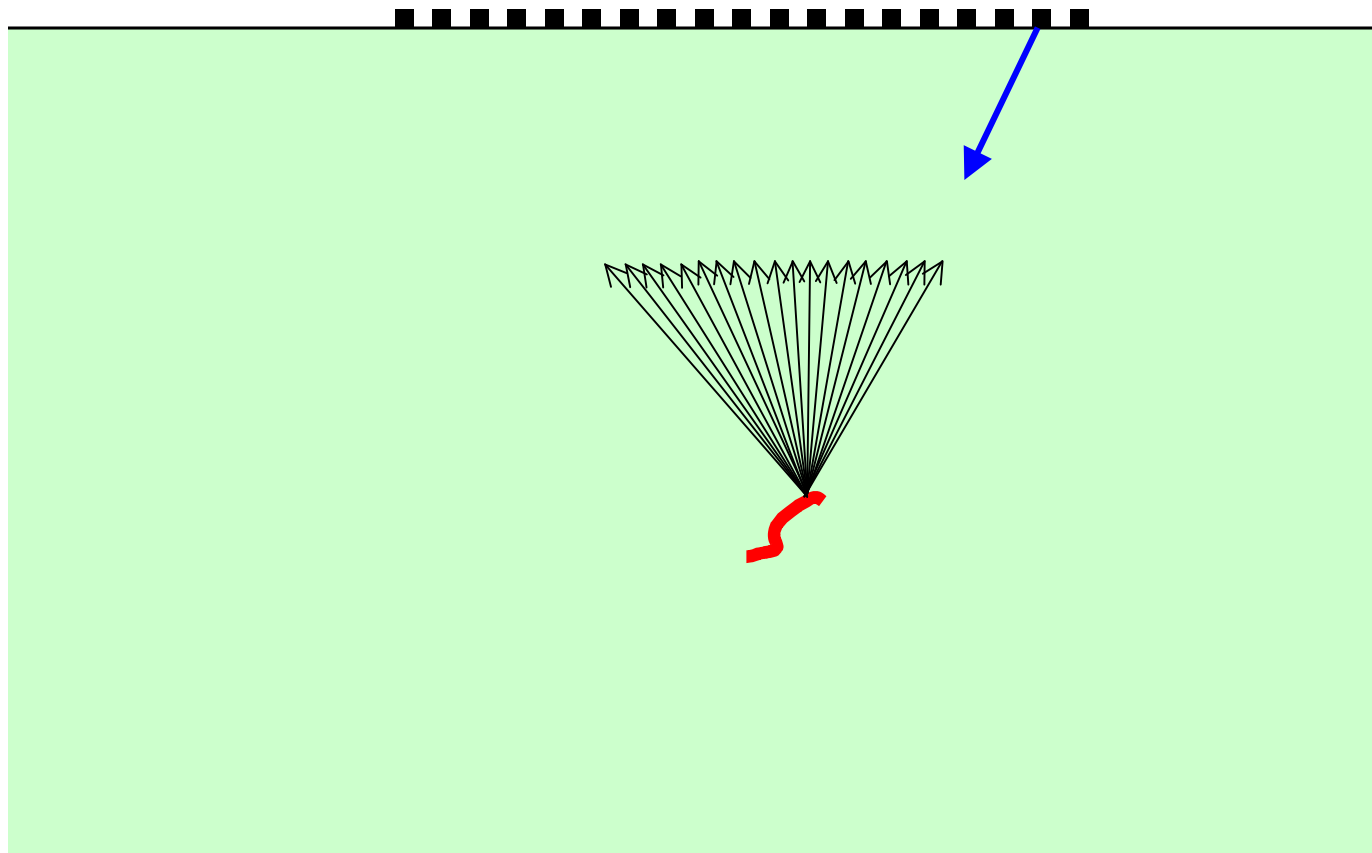

Recent advances in aerospace inspection with ultrasonic phased arrays
Aerospace Testing Expo2007, Munich

Array distributed data collection

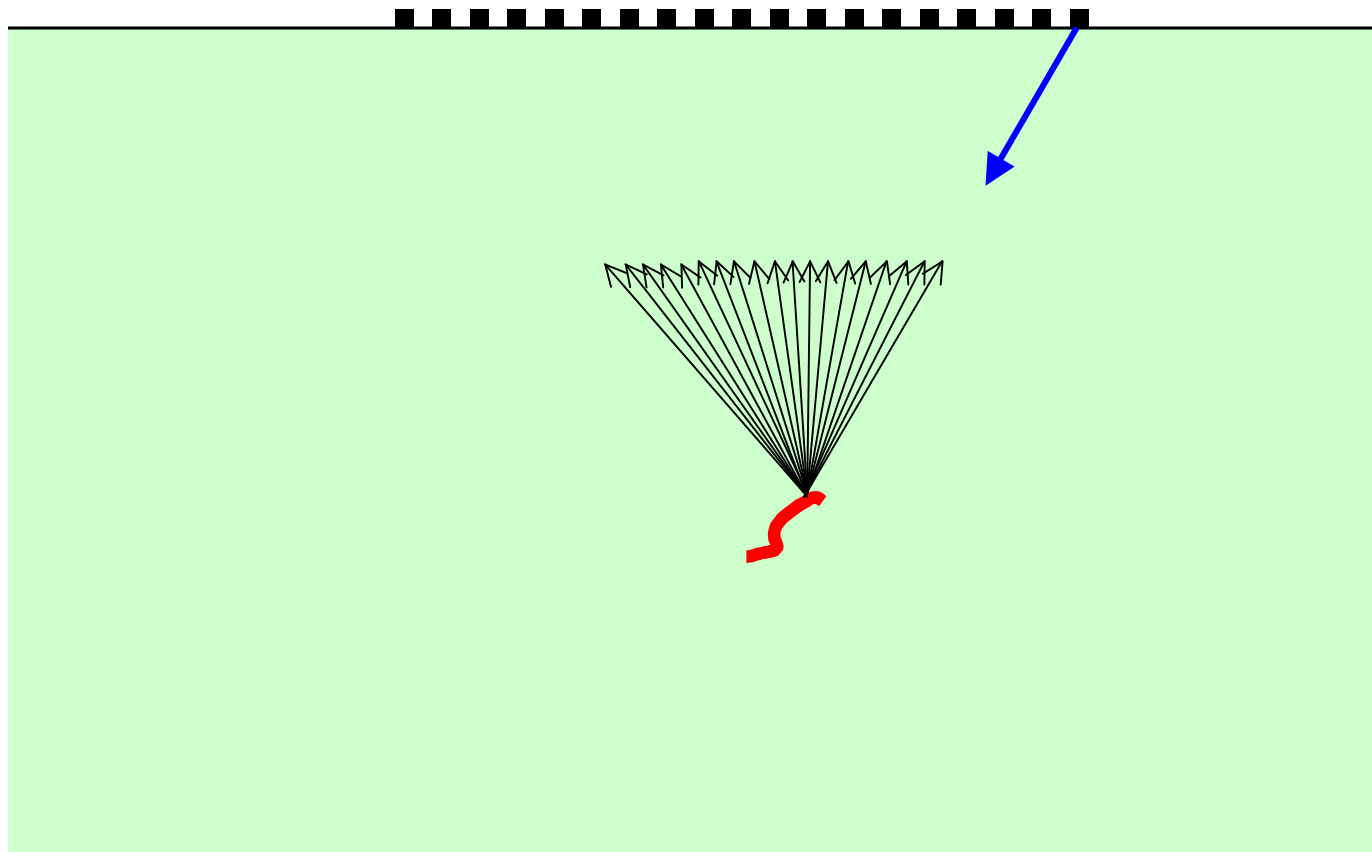

Recent advances in aerospace inspection with ultrasonic phased arrays
Aerospace Testing Expo2007, Munich

Array distributed data collection

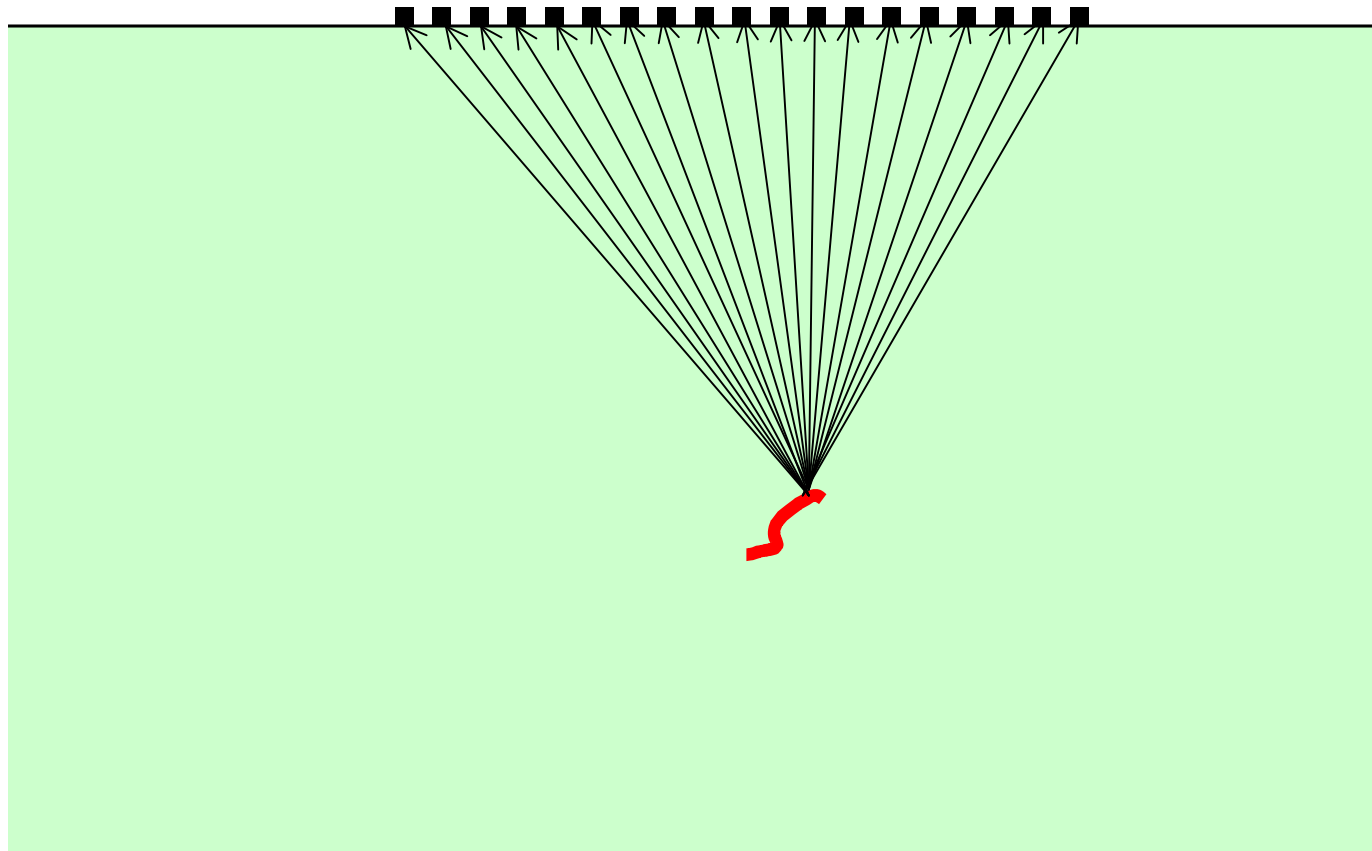

Recent advances in aerospace inspection with ultrasonic phased arrays
Aerospace Testing Expo2007, Munich



Why do Distributed Data Collection?

- Can now implement operations, currently only possible at acquisition, as post-processing
 - Steer angle
 - Focus
 - Aperture size and shading
- New operations, including:
 - Dynamic Transmit Focusing
 - Compounding
 - Non-linear
- Data storage
 - Separation of acquisition and processing



Key requirements for field use

- Rapid acquisition essential for:
 - Maintaining area coverage rate
 - Real-time response for interactive scanning
 - Maintaining coherence across data when array moving with respect to target



Constraints - Dynamic range

- Reduced excitation aperture
 - Wider transmit beam
- Greatly reduced energy reflected

Beamforming can recover SNR as long as:

- Adequate amplitude resolution
- No saturation



Constraints - PRF

- Aim is maximum PRF compatible with material properties
- Constrained by velocity, attenuation and geometry of target material (and of any acoustic delay line)
- Zero inertia of electronic scanning allows interlaced beam sequencing for arrays
- However, the broader transmit beam means interlacing offers much less benefit for Distributed Data Collection

Scan sequence - complete

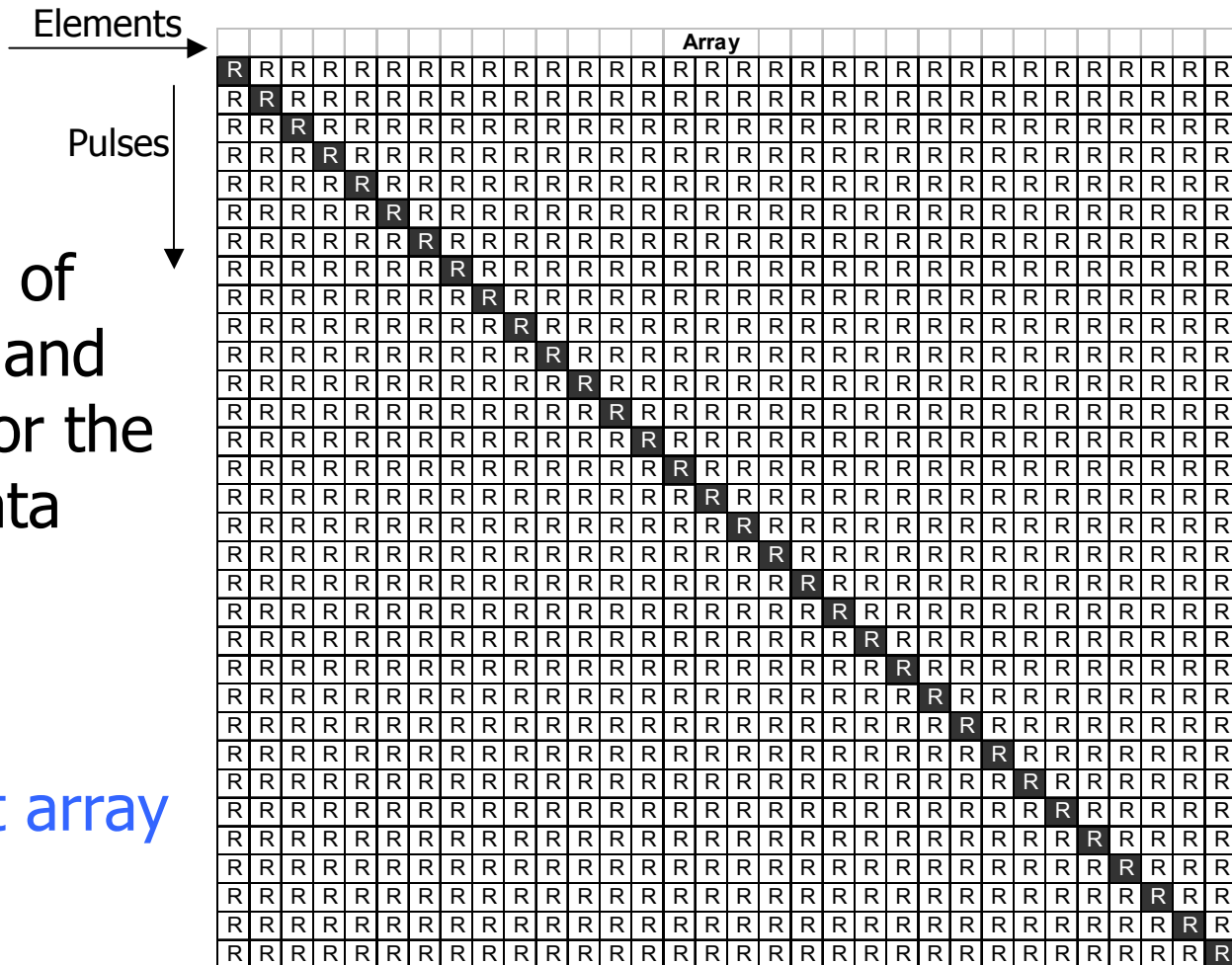

Combinations of Transmit "■" and Receive "R" for the ultimate in data acquisition

N x N pairs
for N element array





FRD frame rate example

- 64 element 5MHz 67mm array
 - 33mm max reconstruction aperture
 - 8 parallel acquisition channels
- 208 pulses per FRD frame
- 96Hz frame rate for 20kHz PRF



Modular implementation

- Array interface
 - Independent control of Tx and Rx positions
 - Programmable beam sequencing
 - Tx beamformer for directional capability
- Digitizer
 - High PRF capability
 - Full waveform acquisition
 - Capable of parallel channel acquisition
- System
 - Position sensing for volume coverage
 - Real-time reconstruction on-the-fly
 - Networking and high density storage



File format

- Requirements
 - Flexible enough for acquisition sequences
 - Must handle volume data sets
 - Open source for application specific algorithms
- Solution
 - Based on extension of AVI file format
 - Matched configuration file holding data on: array, AVI line sequence, aperture and beamformer



Potential Applications

- Optimised imaging
- Complex/multiple array processing
- Target-dependent processing
- Non-linear processing
- Compounding
- Multi-angle skewing for crack detection



Optimised imaging

- Dynamic focus on transmit
 - Continuous rather than zoned
 - No longer needs exact properties at Tx
- Variable steer angle
- Aperture control
 - Variable / dynamic aperture
 - Optimised shading
- Correction of array non-uniformities

Multiple arrays

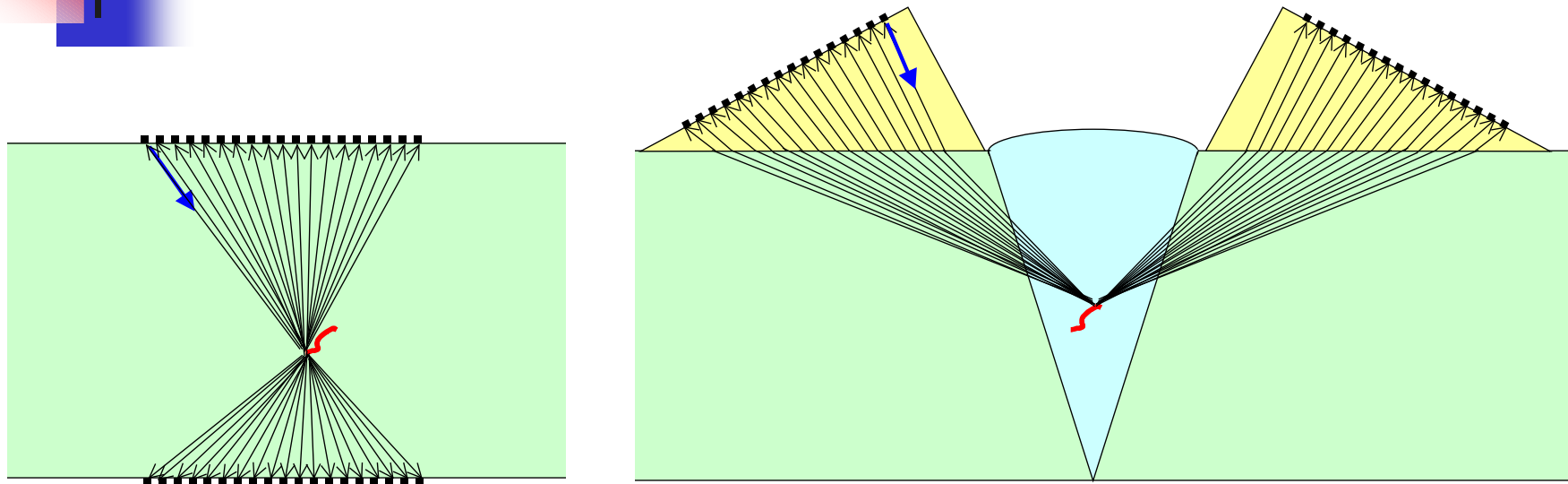

- Conventional pulse echo images from each
 - Thru-transmission / Pitch-Catch images
 - Customized processing
- ... and all from same single-pass data set



Target-dependent processing

- Progressive focusing dependent on properties of each layer
- Adaptive reduction of unwanted echoes
 - Cancellation of repeat echoes
 - Null-steering
- Adaptive correction for surface roughness and coupling variation



Non-linear processing

- Conventional beamforming is linear sum of contributions across aperture
- Non-linear combination
 - e.g. multiplicative (log \rightarrow sum \rightarrow antilog)
- Features
 - Enhanced resolution
 - Lobe suppression
 - Good for discrete targets but anomalies when echoes from multiple targets interact

Non-linear processing example#1

Carbon fibre Composite

5MHz RF image of 2 side-drilled holes in CFC block with 6mm aperture

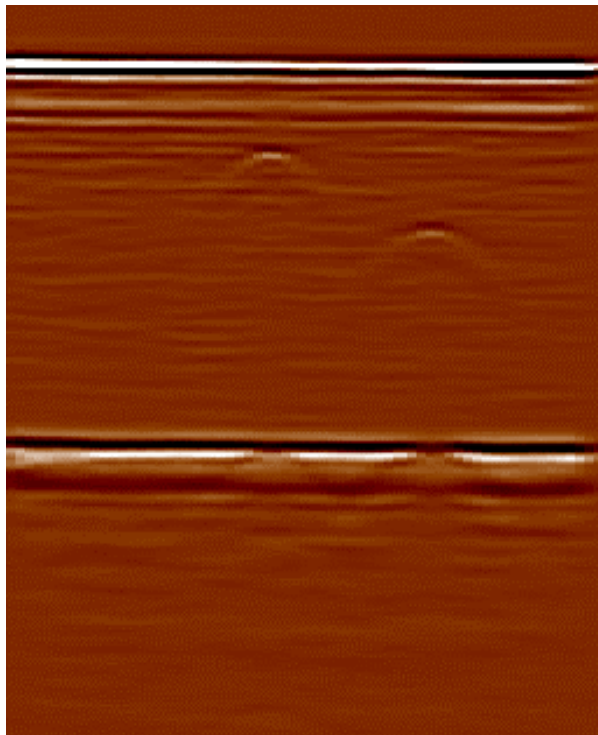

Standard processing

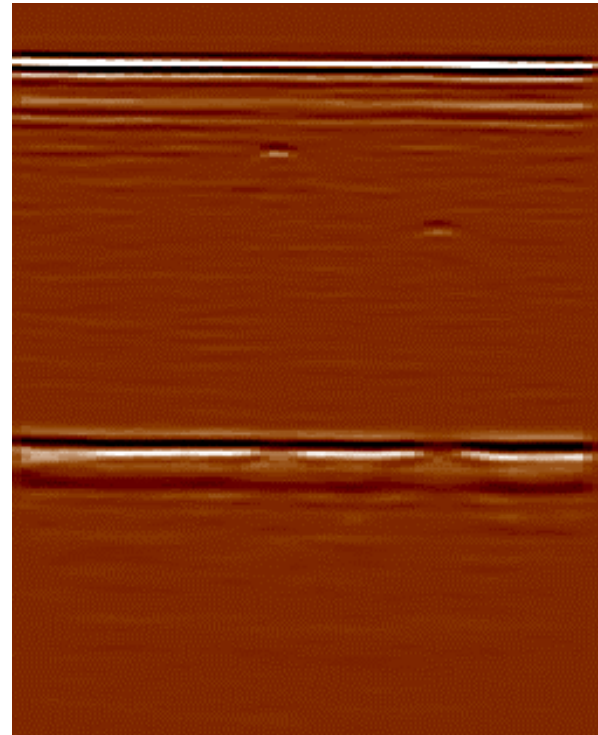

Non-linear processing

Recent advances in aerospace inspection with ultrasonic phased arrays
Aerospace Testing Expo2007, Munich





Compounding

- Fusion of data from different views
- Combination options
 - Incoherent - better view and measurement
 - Coherent - enhanced resolution
- Benefits
 - Improved detection and characterizing of specular reflectors
 - Reduction of speckle artifacts
 - Enhanced resolution and measurement

“Conventional” compounding

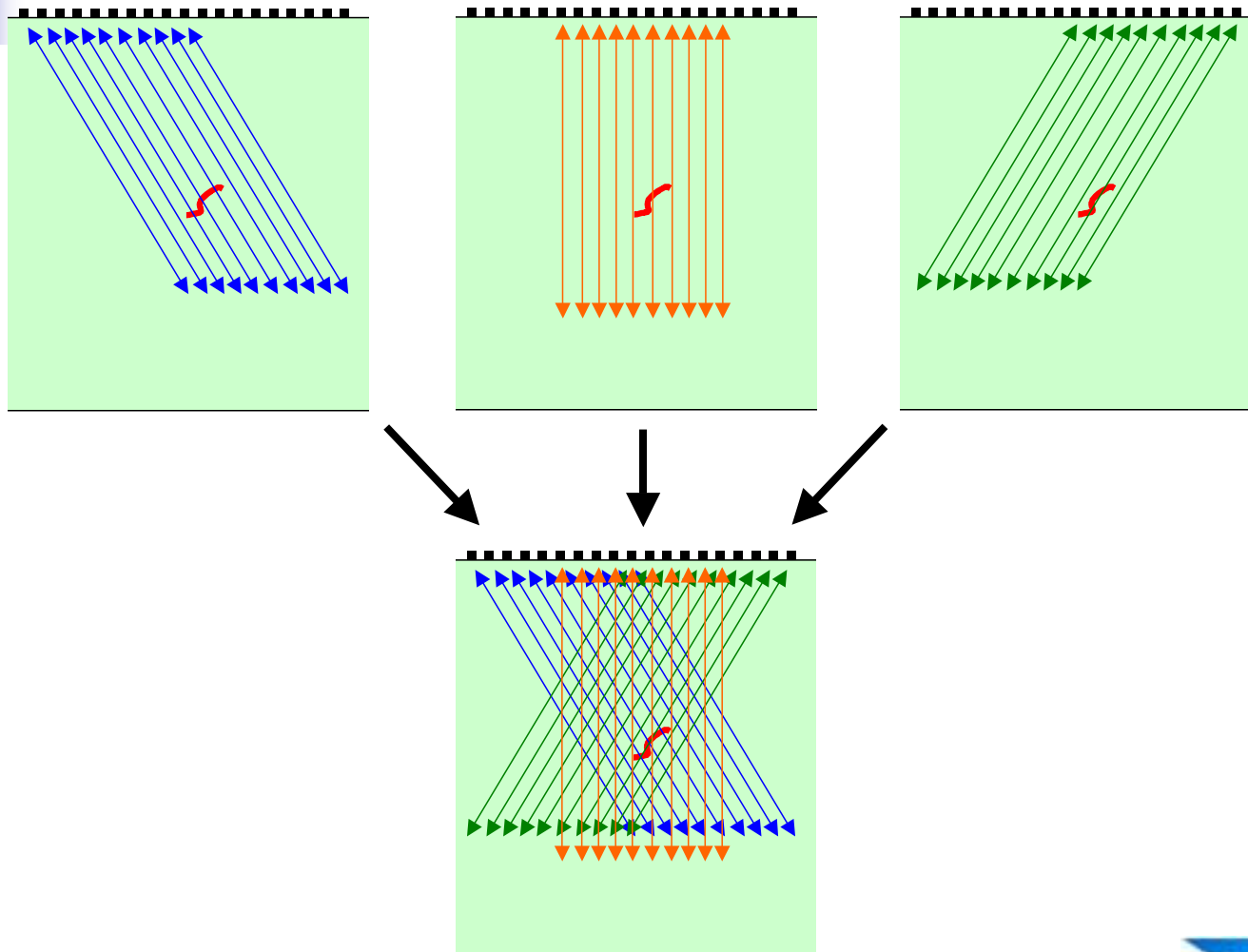

Recent advances in aerospace inspection with ultrasonic phased arrays
Aerospace Testing Expo2007, Munich

Compounding for Spar Inspection

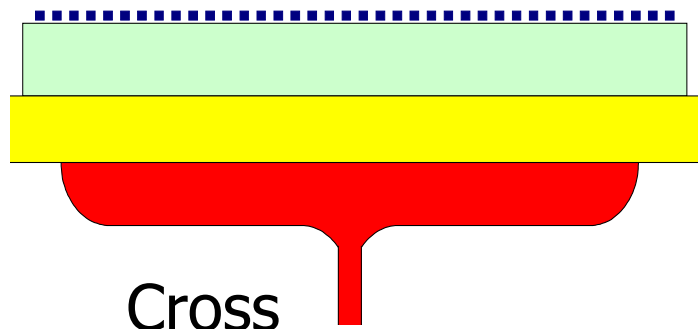

Cross
section
view

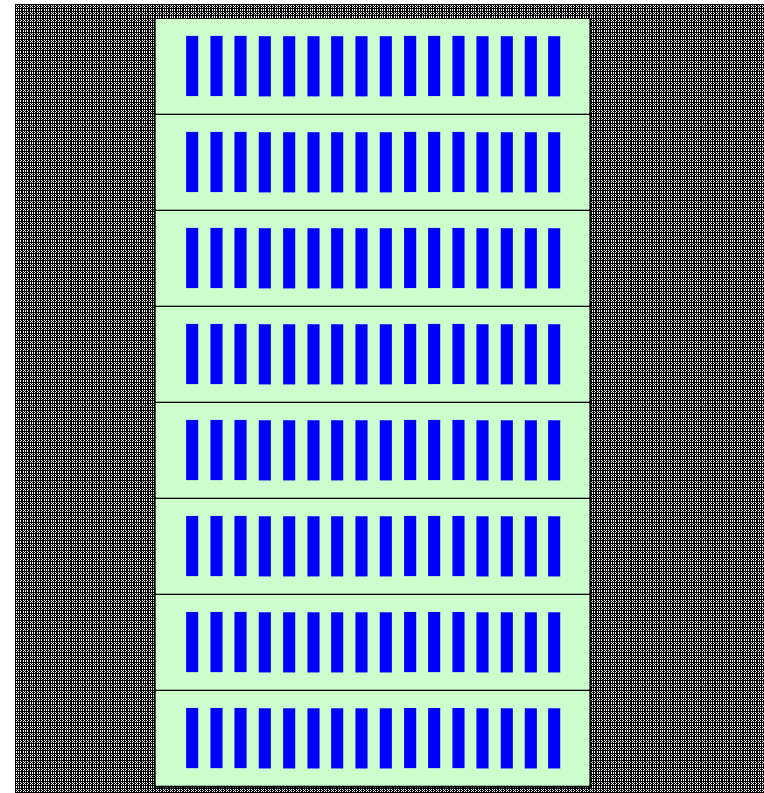

Plan view

Recent advances in aerospace inspection with ultrasonic phased arrays
Aerospace Testing Expo2007, Munich

Diagnostic Sonar

Compounding for Spar Inspection

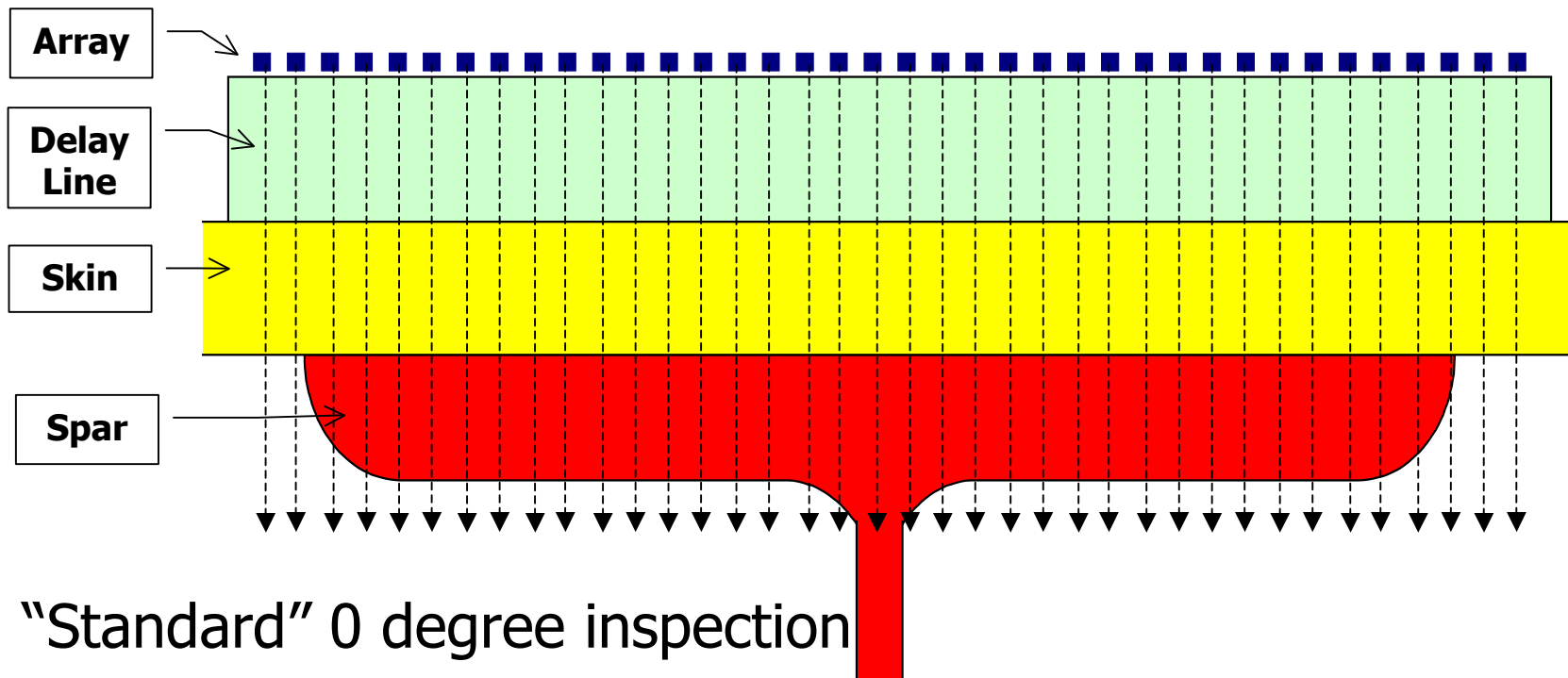

"Standard" 0 degree inspection

Checks for bond integrity, porosity and damage

Compounding for Spar Inspection

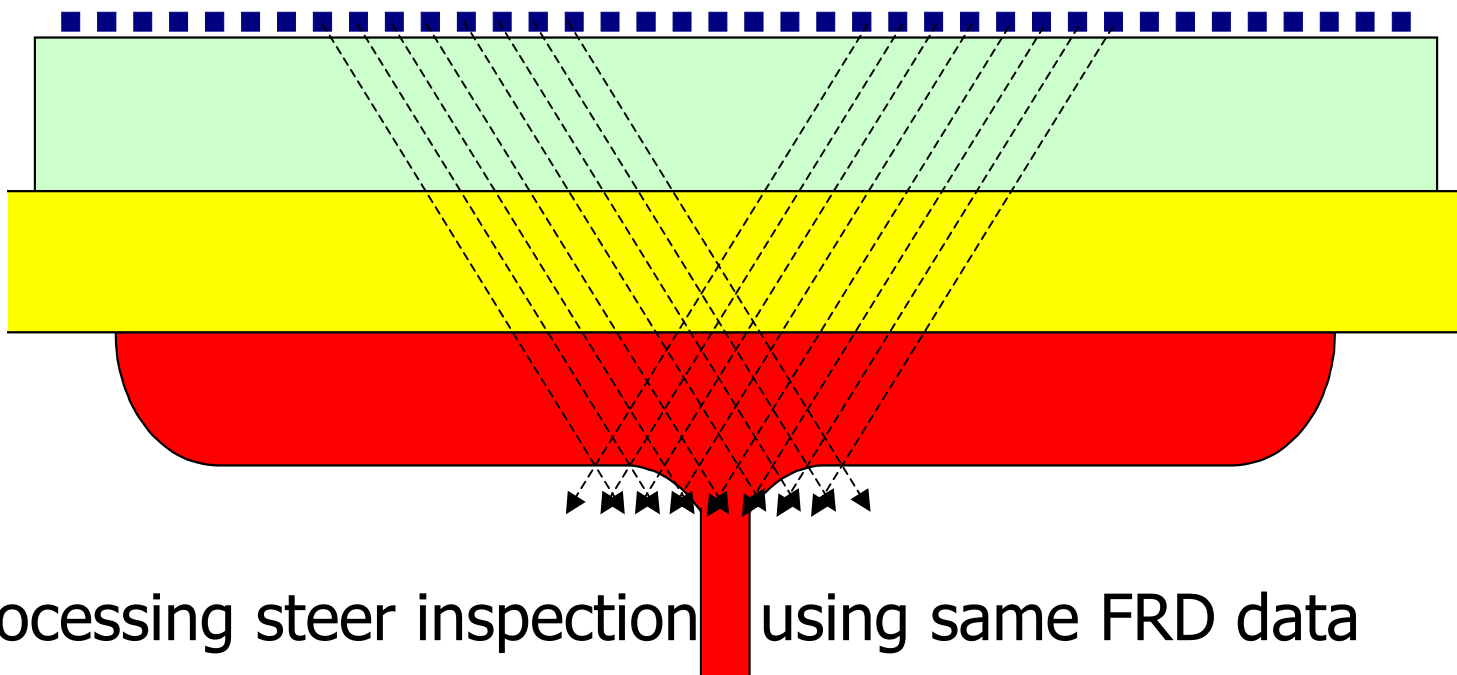

Post-processing steer inspection using same FRD data
Checks for problems in corners

Compounding with virtual array

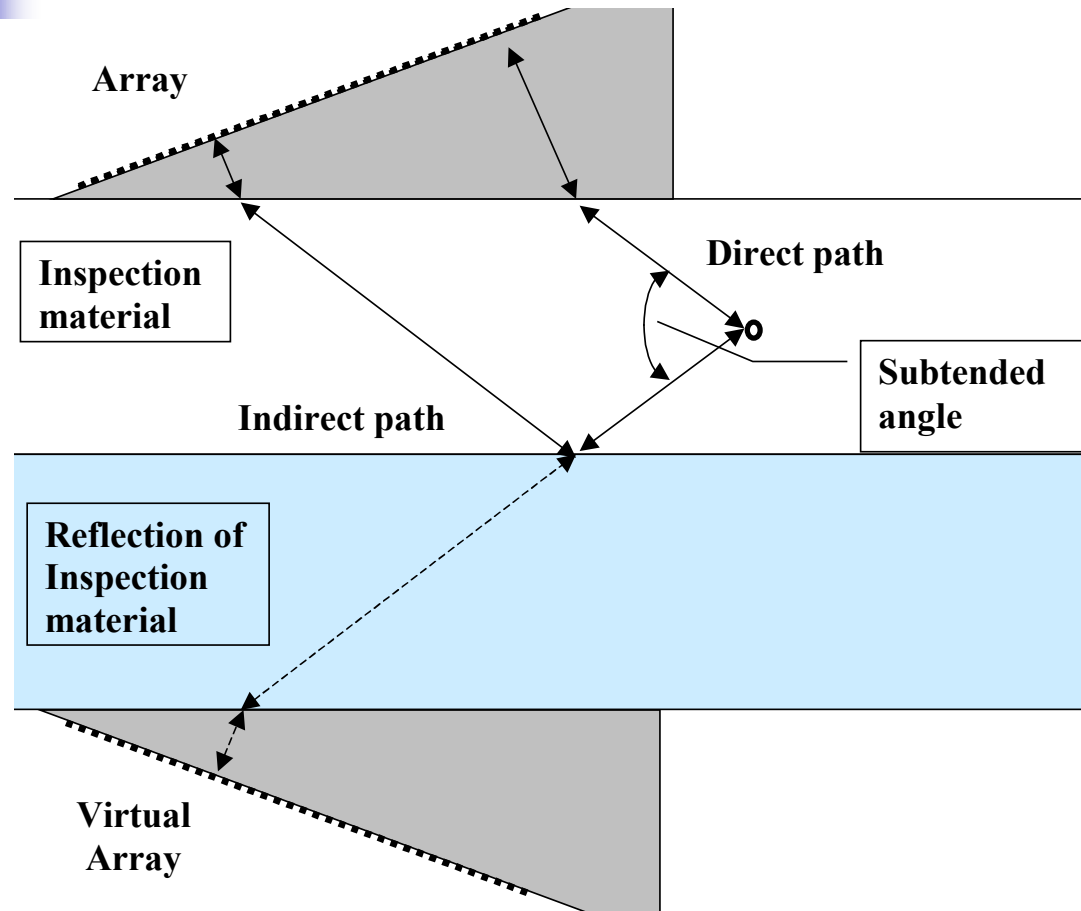

Recent advances in aerospace inspection with ultrasonic phased arrays
Aerospace Testing Expo2007, Munich



Incoherent compounding

Direct echoes

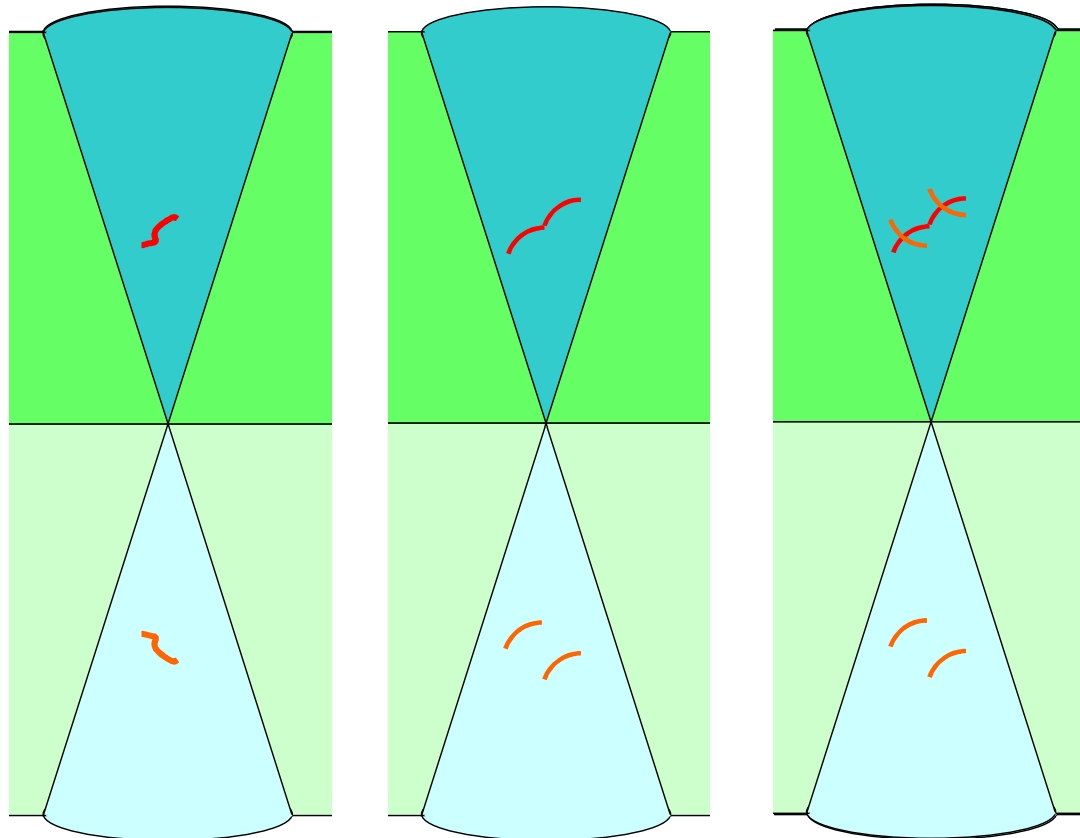

Virtual image

Echoes

Processed

Recent advances in aerospace inspection with ultrasonic phased arrays
Aerospace Testing Expo2007, Munich

Diagnostic Sonar

Incoherent compounding Results

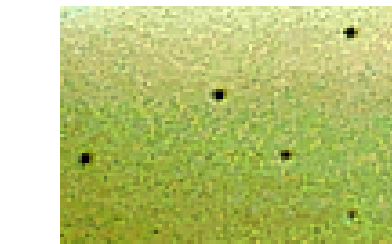
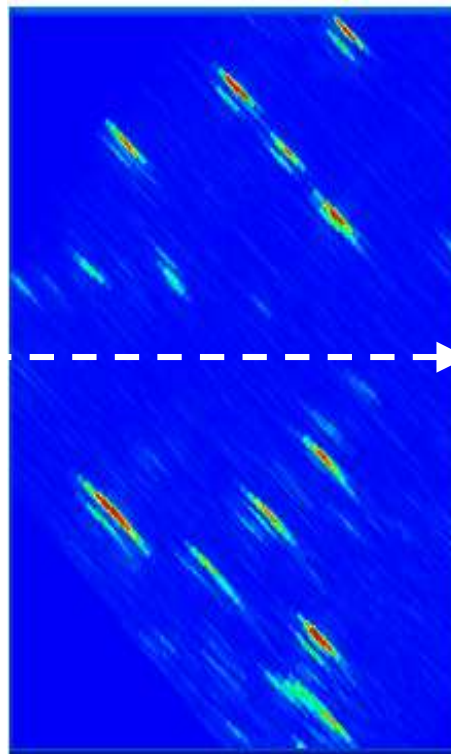

Photo of side-drilled holes in test block

B-Scan of test block



Direct image

back wall

Reflected (virtual) image

Processed Results

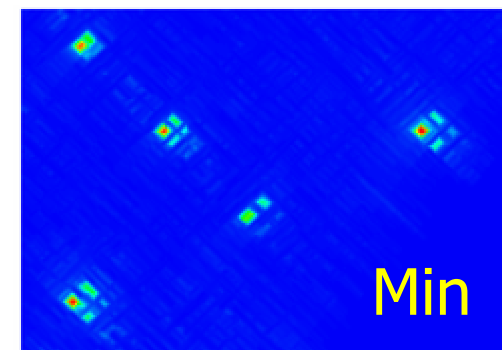
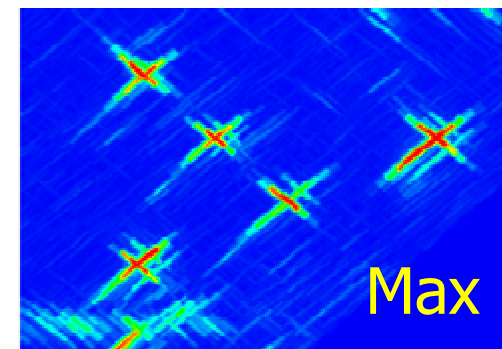

Crack detection Longitudinal Scan

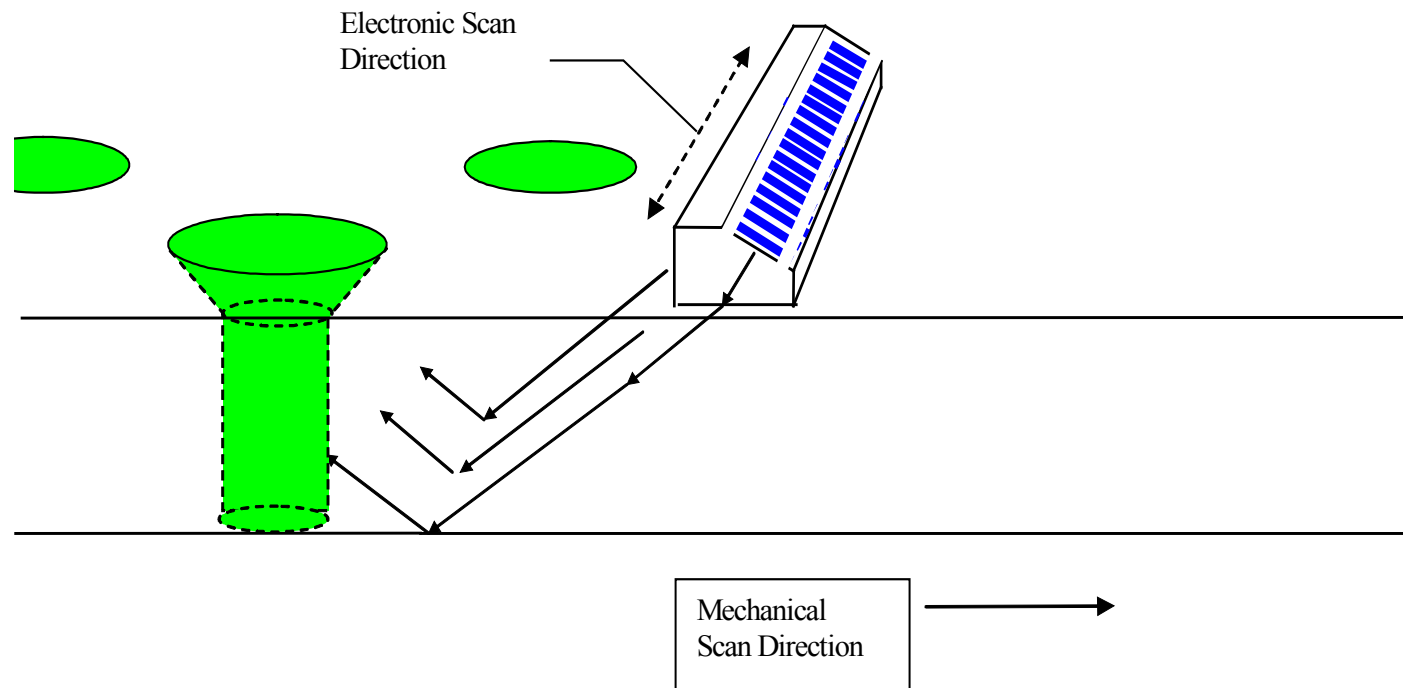

Recent advances in aerospace inspection with ultrasonic phased arrays
Aerospace Testing Expo2007, Munich

Crack detection Longitudinal Scan

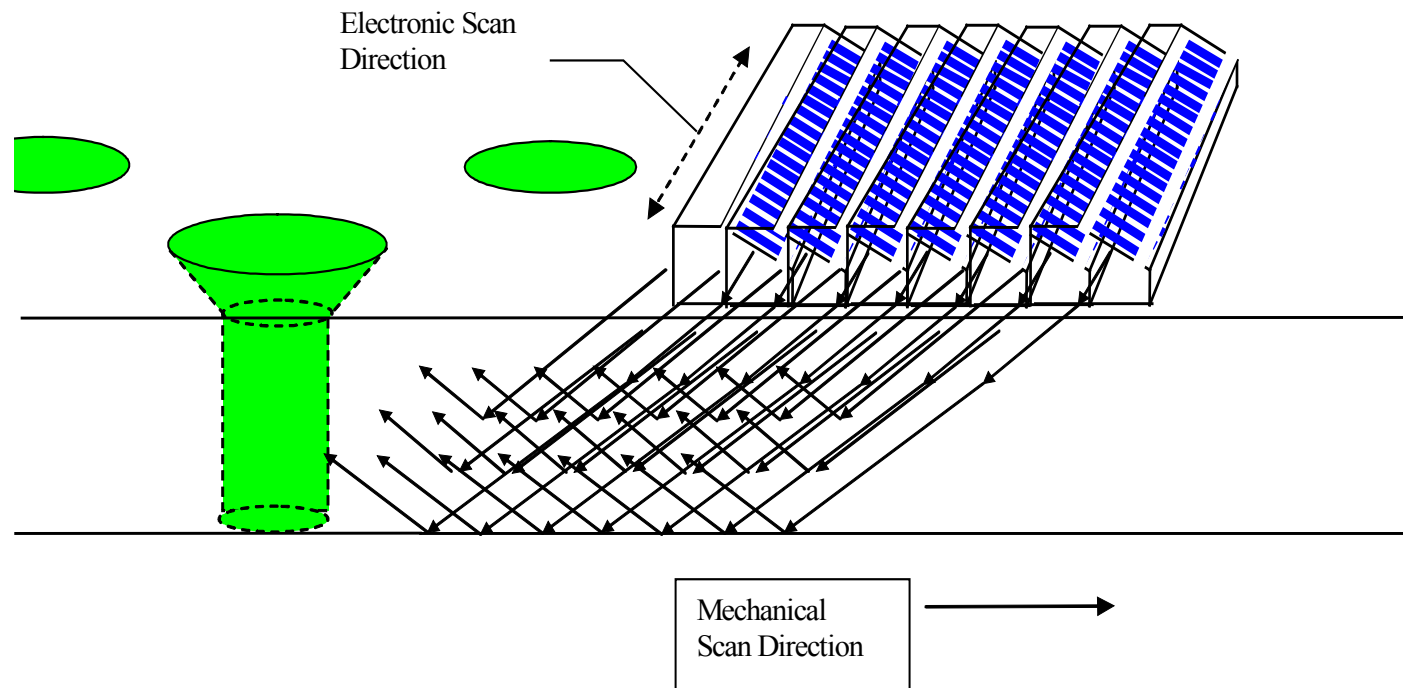

Recent advances in aerospace inspection with ultrasonic phased arrays
Aerospace Testing Expo2007, Munich

Angled beam configurations Longitudinal Scan

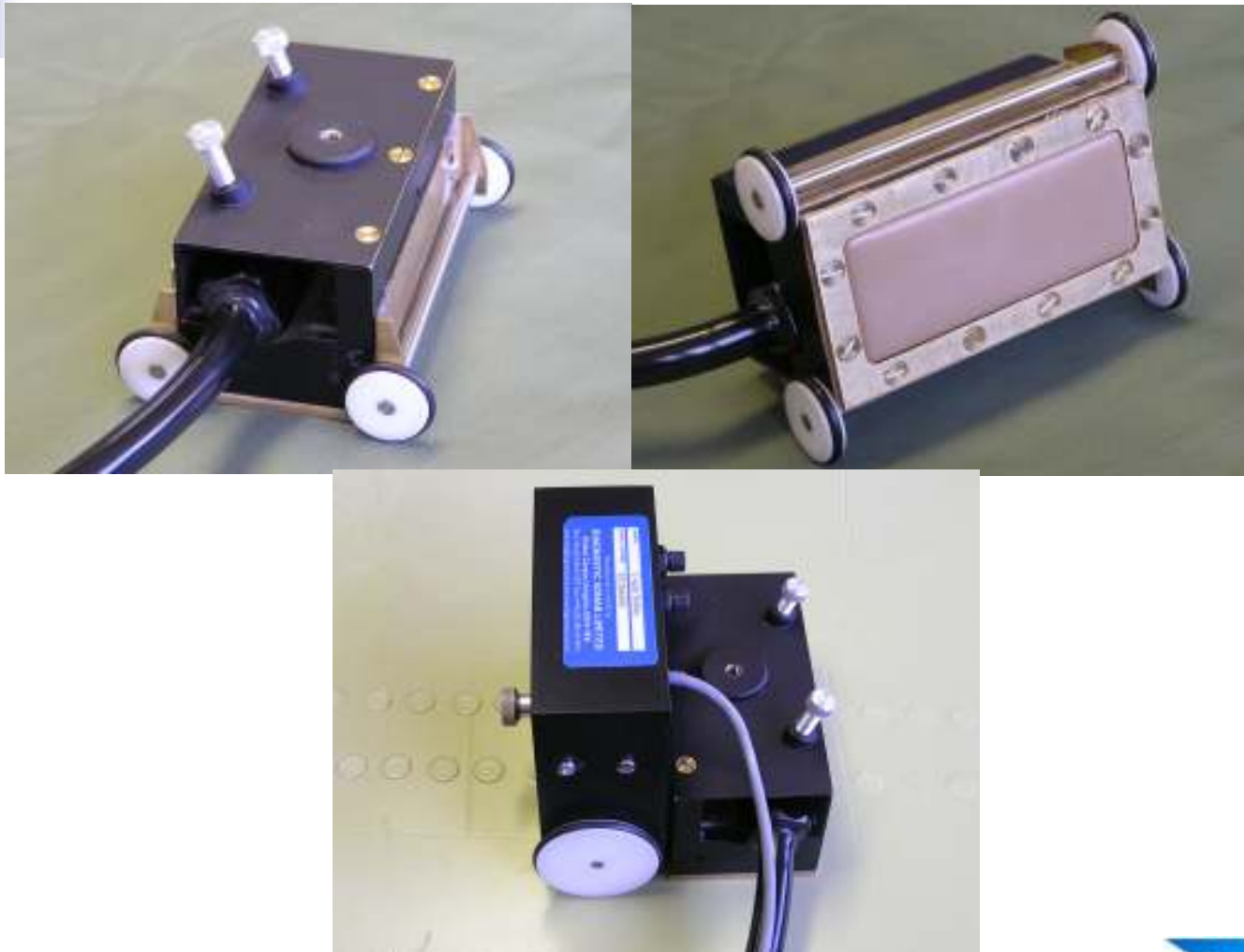

Recent advances in aerospace inspection with ultrasonic phased arrays
Aerospace Testing Expo2007, Munich

Diagnostic Sonar



Response for cracks at any orientation

- Must inspect at multiple angles unless cracks are at a known orientation
- Skewed beams from array reduces number of mechanical scans
- Number of discrete angles depends on:
 - Flaw response vs. angle
 - Acceptable threshold (for false call rate)

Crack response vs. angle

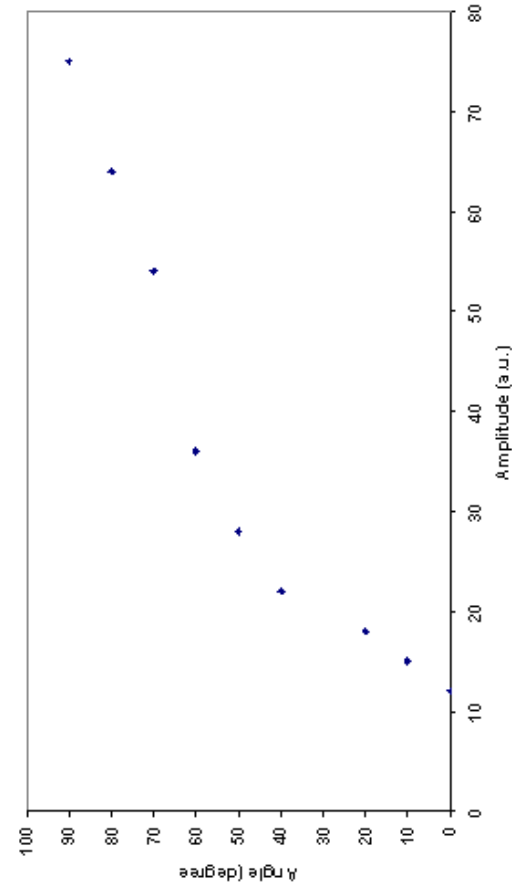
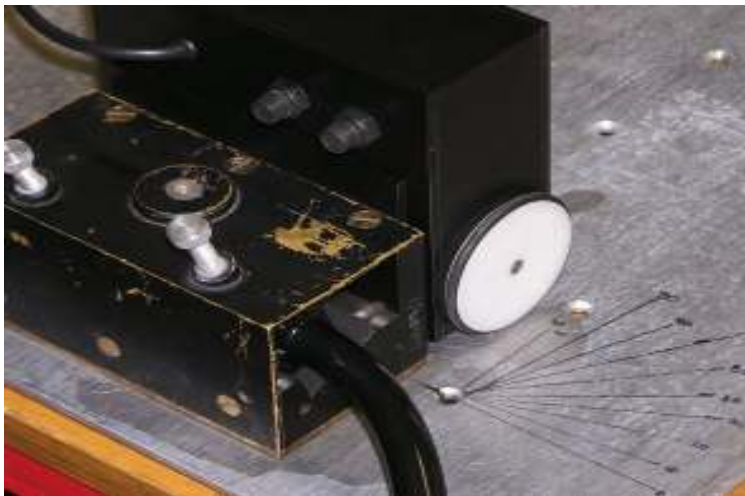
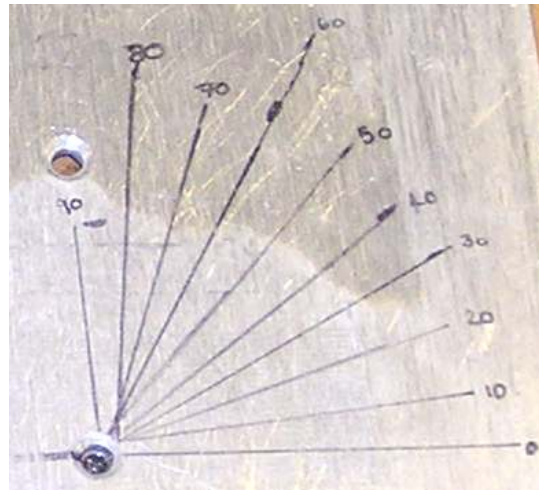

Recent advances in aerospace inspection with ultrasonic phased arrays
Aerospace Testing Expo2007, Munich



Advantages of FRD for cracks

- Conventional beam forming
 - Multiple frames scanned at different angles
 - Trade-offs from discrete angles
 - Number of false calls vs. number of angles
 - Number of angles vs. scan speed
- FRD acquisition
 - As many angles as required from single scan so no trade-off with false calls
 - Potential benefits from other processing

Flexibility – Freehand inspection FlawInspecta[®] and ANDSCAN[®]



Recent advances in aerospace inspection with ultrasonic phased arrays
Aerospace Testing Expo2007, Munich

Diagnostic Sonar

Flexibility – semi-automated scan FlawInspecta® and KitScanner™

- Made from light-weight extrusions
- Measures probe pointing direction
- Probe scanned in single axis

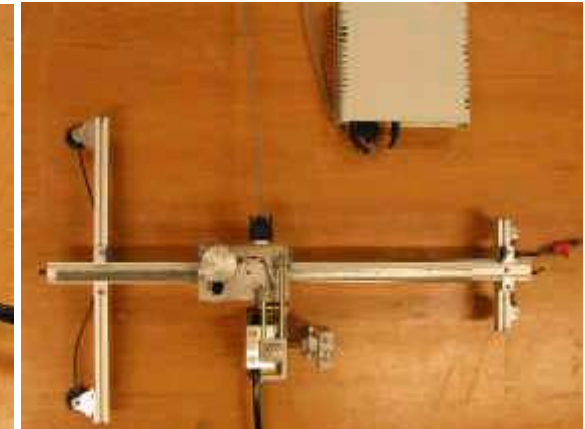
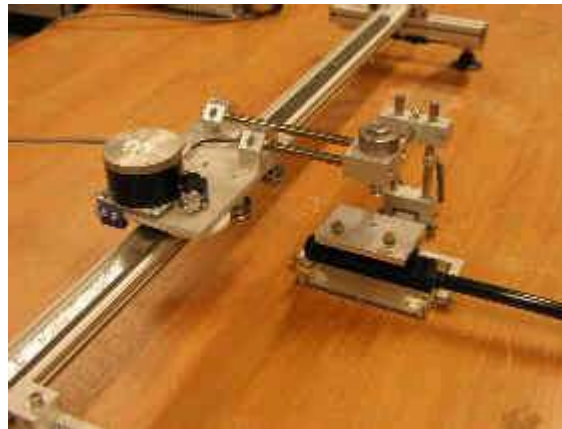
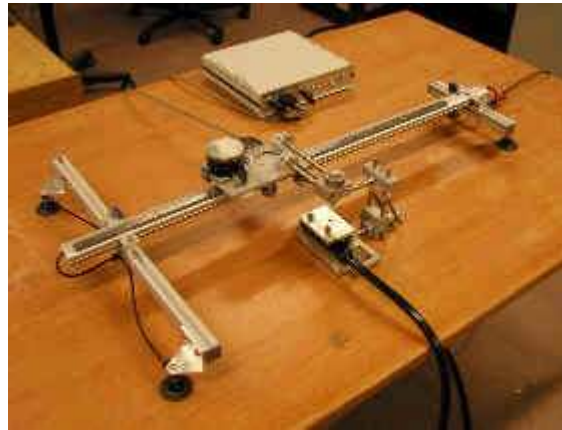

Light-weight Single-axis KitScanner™ + ANDSCAN® software

Recent advances in aerospace inspection with ultrasonic phased arrays
Aerospace Testing Expo2007, Munich

Diagnostic Sonar

Problems with interpretation due to complicated geometry

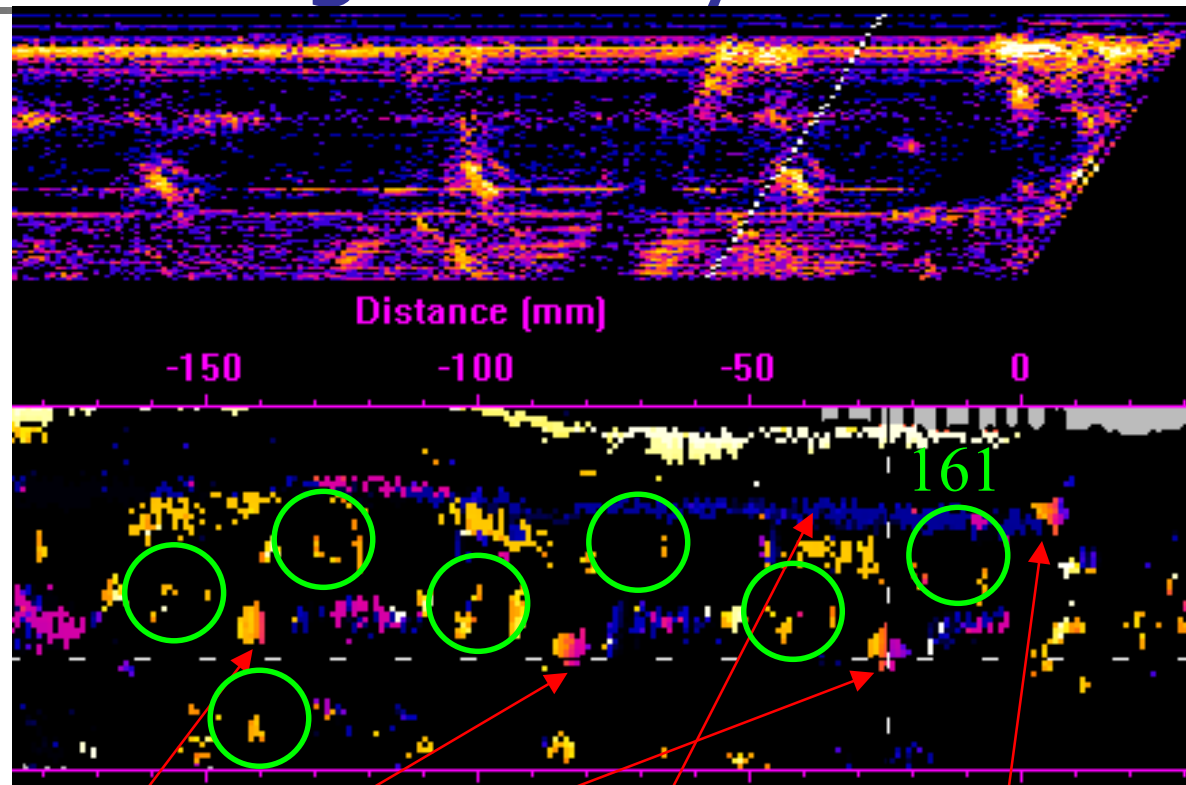
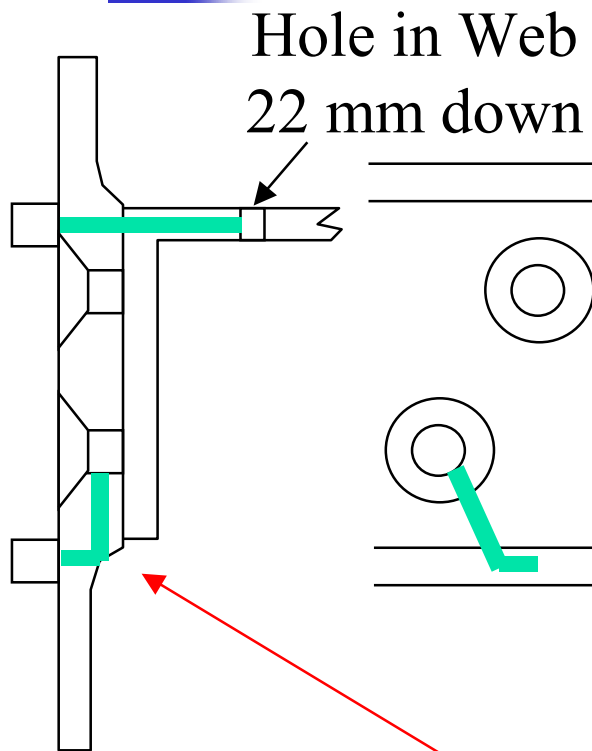

Complex reflections

Web

Hole in Web

Recent advances in aerospace inspection with ultrasonic phased arrays
Aerospace Testing Expo2007, Munich

Diagnostic Sonar

Multi-layer Ultrasonic Crack Detection

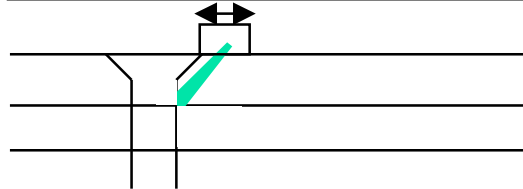
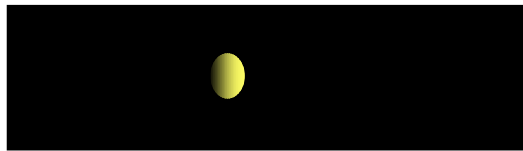

1/2 skip to back of 1st layer

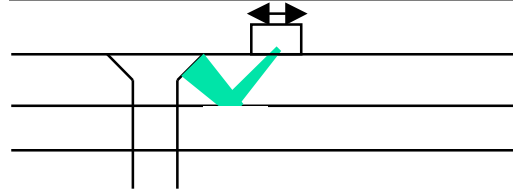
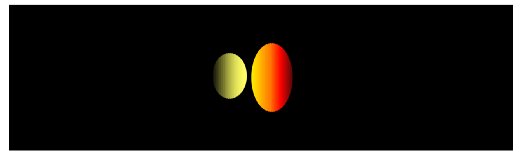

Full skip to Countersink

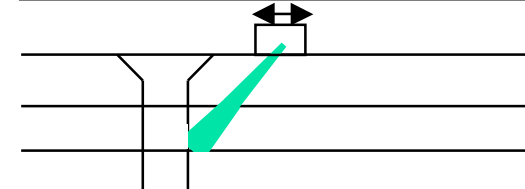
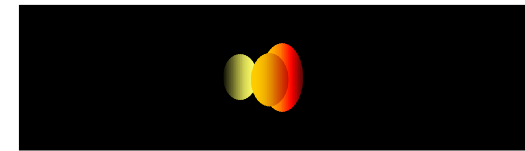

1/2 skip to back of 2nd layer

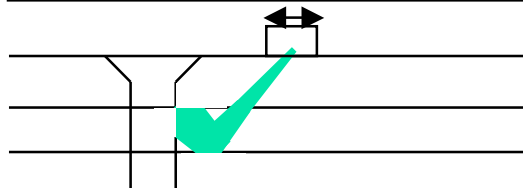

Full skip to front of 2nd layer

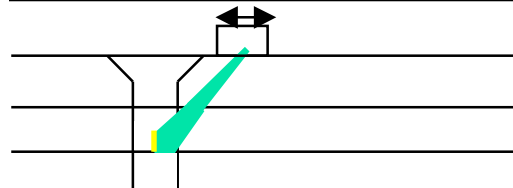
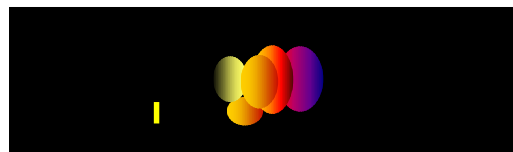

Crack at front of 2nd layer

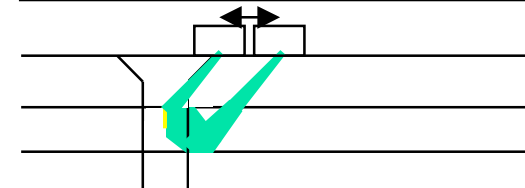

Crack at back of 2nd layer

Recent advances in aerospace inspection with ultrasonic phased arrays
Aerospace Testing Expo2007, Munich

Diagnostic Sonar

Results

5MHz 17mm Aperture (ERM)

- All 14 Spark-eroded slots found:
 - 6 off 0.5 mm
 - 4 off 1.0 mm
 - 6 off 1.5 mm

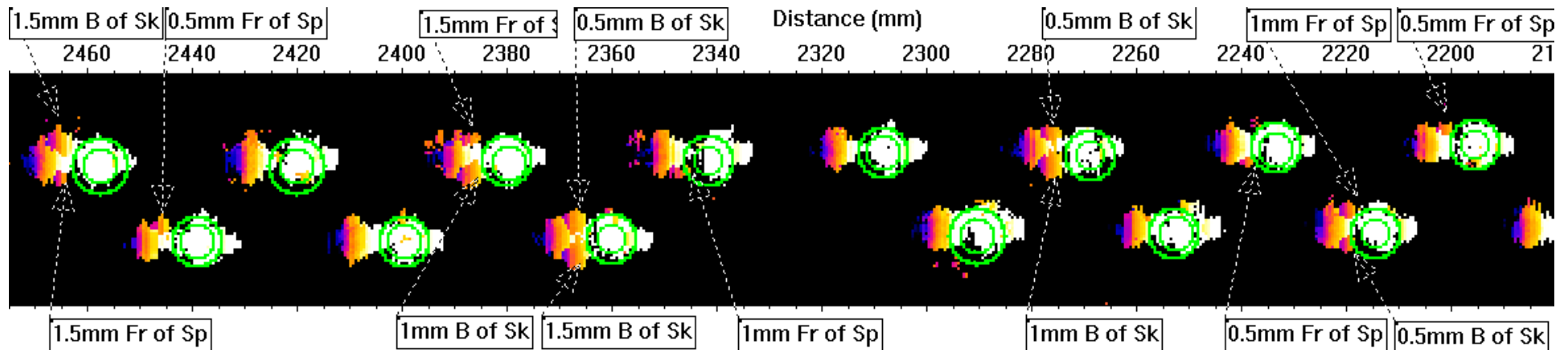

Recent advances in aerospace inspection with ultrasonic phased arrays
Aerospace Testing Expo2007, Munich

Diagnostic Sonar



3D Visualisation

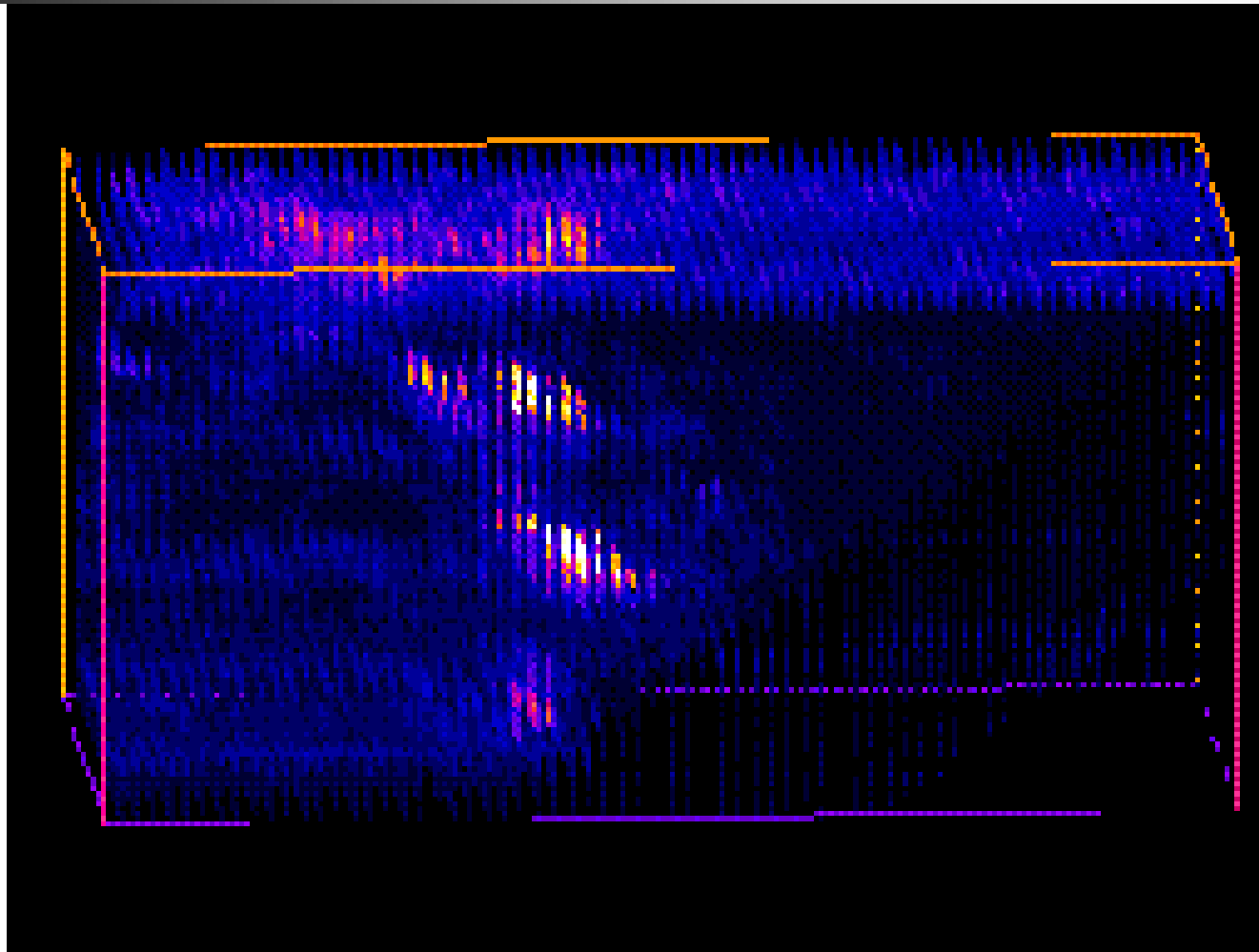

Recent advances in aerospace inspection with ultrasonic phased arrays
Aerospace Testing Expo2007, Munich

Diagnostic Sonar



Summary

- Full Raw Data collection is logical step after FWC
 - Extended post-processing capability
 - Many additional non-imaging processing options
- Separate acquisition and reconstruction
- Rapid acquisition essential for field use
- Implemented in modular hardware
- Open file format for user-generated algorithms
- Many applications - some already “work in progress”
- Commercial implementation



Acknowledgements

- QinetiQ Ltd., NDE Group, Farnborough
 - Robert Smith, Lyn Jones, David Edgar, Jamie Bending
- University of Paisley, Microscale Sensors
 - Irene Pettigrew